

Commercial aluminium door to be fabricated in accordance with manufacturers specification
doors to be strengthened to suit size and conditions

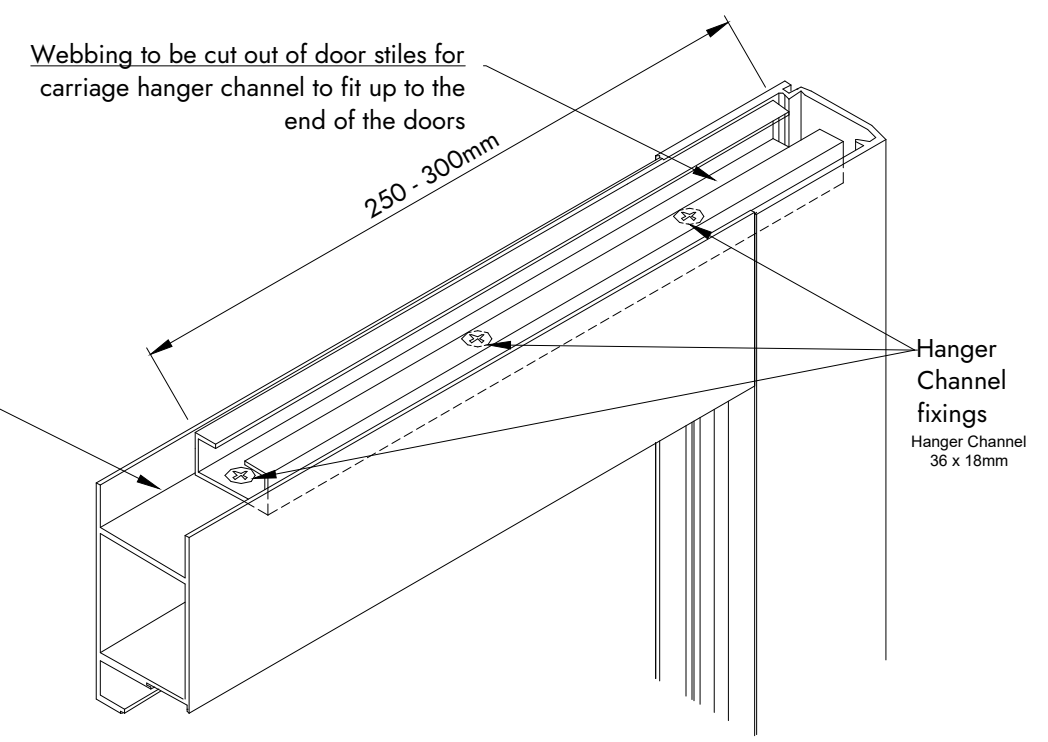

CARRIAGE HANGER CHANNEL FIXING

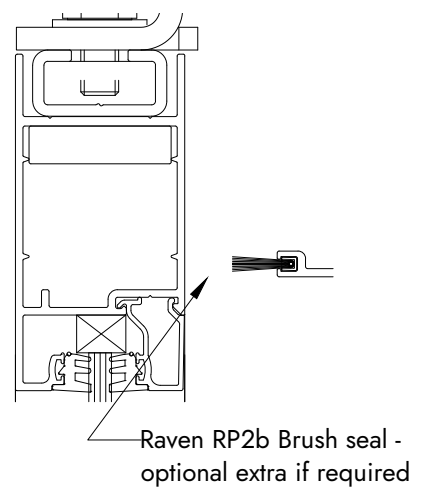
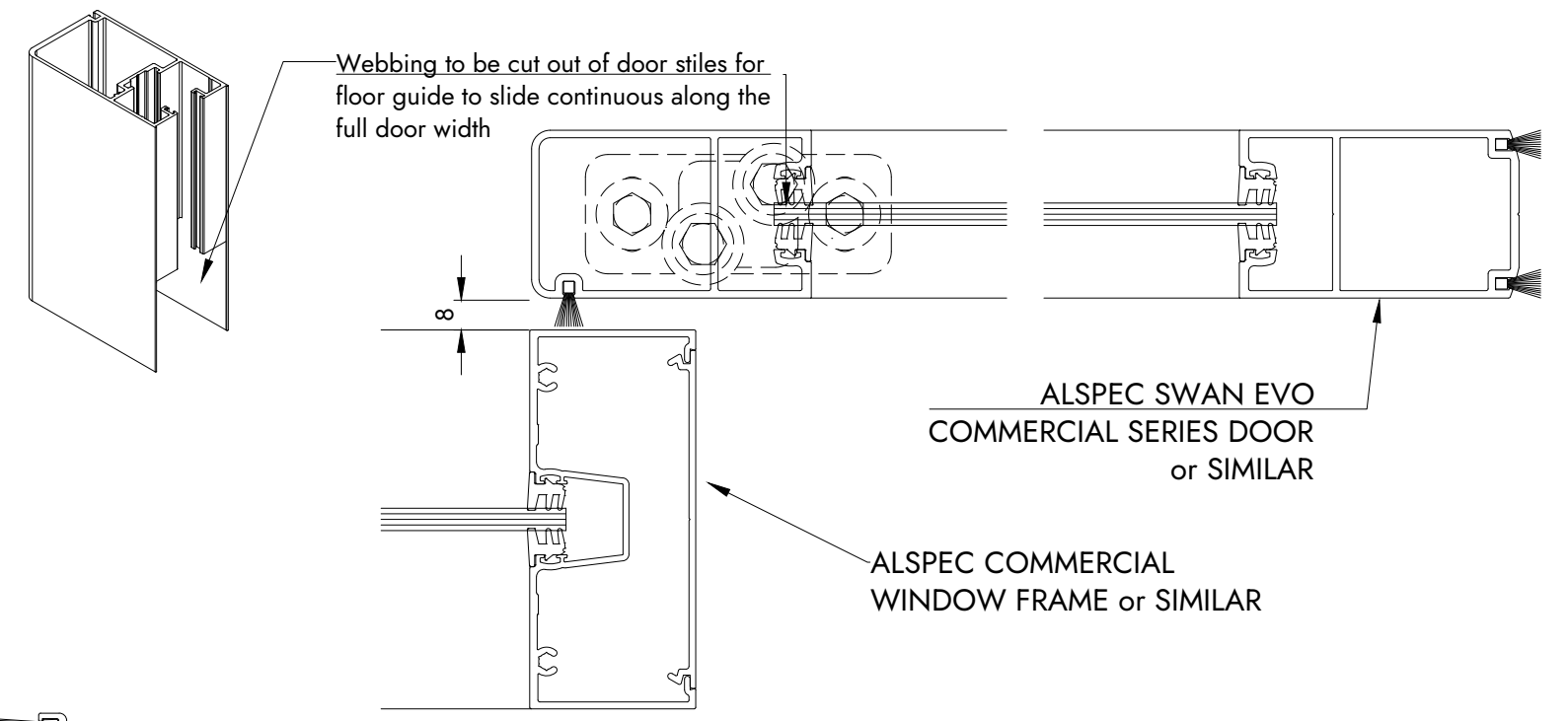

sales@recorddoors.com.au / www.recorddoors.com.au

| | | | | |
|-----------------------------|-------------------------------|--------------|------------|-------------------------|
| DRAWN : PPG | OPERATOR WEIGHT CAPACITY (kg) | | | MODEL : RECORD STA 22H |
| DATE : SEPTEMBER 2023 | OPERATOR | SINGLE SLIDE | BI-PARTING | PELMET : 250mm PROFILE |
| SCALE : 1 : 2 | STA 22H | 1 x 400 | 2 x 300 | DOOR : ALUMINIUM FRAMED |
| DRG NO : STA22H-250-FRD (A) | STA 22H (2 off) | - | 2 x 400 | PROJECT : |